

Manufacturers of electrical distribution boxes used in South African factories

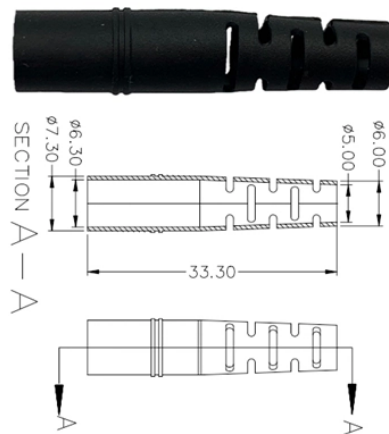

Overview

Brands like York, Okari, Enlec, Utilec ©, PSO1 and PSO2 are well known in the South African market and are all solely manufactured by Allbro in South Africa. Local manufacture to international standards means that products are suited to the rigors of an extremely tough local. Allbro supplies key components that are used in almost every locally made transformer. With the acquisition of ABB's South African enclosure business (York) in 2011, Allbro also became a leading supplier of non-metallic enclosures to the industrial, commercial and residential contracting trades. Power Process Systems is an electrical enclosure and distribution equipment manufacturer. Golnix is situated in George (Southern Cape). We supply products throughout South Africa, Namibia and Africa. Based in Cape Town, South Africa, Polybox has a very simple mission to design and manufacture high-quality electrical. Modular devices for circuit protection and indication in power distribution system Plastic, steel, stainless steel waterproof enclosure and single & three phase DB British, European, American type wall switch and socket for various option

DC voltage rated products for installation and circuit.

Manufacturers of electrical distribution boxes used in South African



Brands like York, Okari, Enlec, Utilec ©, PSO1 and PSO2 are well known in the South African market and are all solely manufactured by Allbro in South Africa. Local manufacture to international ...



Driven by a need for quality enclosures that are delivered on time, Electro Systems management team made the decision in 2012 to expand their business to include a sheet metal plant.



Gem Switchgear is a leading distribution board manufacturer in South Africa. We also manufacture a comprehensive range of low and medium voltage switchgear.



We are Electrical & Switchboard Manufacturers serving the Mining, Metallurgical, Agriculture, Chemical, Petroleum and Industrial sectors. We have been specializing in the Electrical, Instrumentation and ...



Today we supply network distribution equipment to all of the electrical utilities across the country, from Cape Town to Musina. Our clients rely on us to design, develop, manufacture and deliver enclosures ...



Onesto Africa, a veteran electrical product manufacturer, is dedicated to delivering quality-assured products tailored for power distribution, industrial control, photovoltaic systems, and more.



Golnix today supplies products all over South Africa, as well as to Namibia, Botswana, Tanzania, Kenya, Ghana and as far as Saint Helena Island.

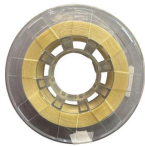

Golnix today supplies products all over South Africa, as well as to Namibia, Botswana, Tanzania, Kenya, Ghana and as far as Saint Helena Island.



Switchboard Group designs, manufactures, and installs Electrical Boards across Southern Africa and abroad. We offer a one-stop turnkey service across a wide range of industries and applications, with ...

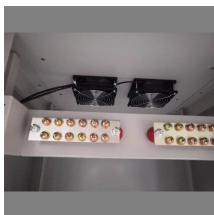

Based in Cape Town, South Africa, Polybox has a very simple mission to design and manufacture high-quality electrical enclosures that withstand the toughest elements. We pride ourselves on being a ...



We specialise in distribution boards, MCCs, electrical starters, enclosures and more. Henelec Switchboards specializes in the manufacturing of power switching products and related equipment, ...

Contact Us

For more information, pricing, or custom network solutions, please contact us:

Website: <https://hashherbcafe.co.za>

Email: hello@hashherbcafe.co.za

Phone: +27 63 814 7295

Address: 15 Galaxy Road, Linbro Business Park, Johannesburg, 2065, South Africa

This document is for informational purposes only. Specifications subject to change without notice.

